



MASTERFLUX

MasterFlux
48V Cascade
BLDC Motor Controller
Product Specification
030F0175

Revision History

Date	ECN	Rev	Description	By
06/03/14	EC59159	A	Initial Release	D. Stahl
12/02/14	EC62786	B	Correct over temperature F	D. Stahl

Table of Contents

REVISION HISTORY	1
TABLE OF CONTENTS.....	2
DEVICE OVERVIEW	3
Features	3
DESCRIPTION.....	3
OPERATION	4
Analog Speed Control (default).....	4
Fixed Speed Control	4
Fault Detection.....	4
LED Fault Indicator and Fault output.....	6
FAN output	6
ENGINEERING SPECIFICATIONS	7
OPERATING CHARACTERISTICS.....	7
ENVIRONMENTAL RATINGS	9
Absolute Maximum Ratings	9
CONNECTORS	10
RoHS Compliance	10

Device Overview**Features**

- **4 poles sensor-less variable speed BLDC motor controller**
- **420W maximum output power**
- **39 - 60 VDC input range**
- **1800 – 4200 rpm speed**
- **1.0 - 4.75V analog speed set input (resistor programmable for fixed speed)**
- **0 to +55°C operating temperature (air flow across controller required)**
- **Under/Over voltage shutdown (resistor programmable under voltage thresholds)**
- **Locked rotor detection**
- **Thermal shutdown – for power devices**
- **Over current shutdown – for power devices**
- **Low speed shutdown**
- **TTL Fault output**
- **LED fault indicator**
- **Fan output, +12VDC @ 0.5A with voltage detection**
- **Reverse polarity protection**

Description

The TH motor controller has been designed to provide efficient control and monitoring of a 4 pole 48VDC brushless/sensor-less hermetic TH compressor. The controller will provide a constant speed as specified by the speed command input (1800 - 4200 RPM) unless one of the following limitations occurs:

Power limitation, the controller monitors the average power into the motor if the power into the motor exceeds 420 watts for 60 seconds the controller will fault due to over-current fault.

The compressor on/off operation is controlled by 0V – 5V analog input. For fixed speed applications a resistor can be installed between ground at the controller and the speed input.

(see resistor selection chart)

The controller is designed to work in ambient temperatures from 0°C (32°F) to +55°C (131°F) and presents several fault sensors to protect the module, the power supply and the compressor. Air flow across the controller is required.

Visual Fault information is available through an LED that is uniquely flashed for each fault condition. A TTL fault output is also available that is high when fault is active.



Operation

Analog Speed Control (default)

A 0 - 5VDC non-isolated analog input can be used to control the motor speed, off / on operation. When the analog input is between 0.26 and 0.99V or greater than 4.75V the compressor is off. When the analog input is between 0V and .25V, the compressor will run at a fixed speed of 3000 RPM. If the analog input is above 0.99V and below 4.75V the compressor will start and ramp up at a rate of 600 RPM per second to the commanded speed. The speed command is mapped to 1V is 1800 RPM and 4.75V is 4200 RPM. Once the motor begins to run it will require the input voltage to go lower than 0.8V or higher than 4.75V to stop the motor (hysteresis). The motor controller will run the motor at the set-point speed unless a voltage, current or power limitation is exceeded.

Fixed Speed Control

A fixed motor speed can be set through an external resistor connected between ground at the controller and the speed input. A switch in series with the resistor can be used to turn the motor on and off in this configuration. See speed resistor selection chart.

Fault Detection

The compressor is turned off when any of the faults described below are detected. Faults are indicated on the fault output pin and flashed on the LED. The fan output is disabled for all faults except motor faults where the fan output will continue to be active if the run command is present.

Faults

- **Motor Fault** – If the compressor fails to start the fault output will be activated and a motor fault will be indicated on the LED. The controller will delay for 60 seconds before attempting to restart. Also the compressor must maintain a minimum speed of 1500 RPM for proper lubrication. If the controller is unable maintain 1500 RPM it will turn the compressor off then set the fault output and display motor fault. The controller will delay for 60 seconds before attempting to restart. If a motor fault occurs and the controller is commanded to run the fan output will continue to be active during the 60 second fault timer. All other fault conditions the fan output will be disabled until the fault is cleared.
- **Under/Over voltage** - The controller will continuously monitor the input voltage, if the input voltage exceeds the upper or lower limits it will turn the compressor off and set the fault output and display the appropriate fault message on the LED. The controller will then delay for 60 seconds. After the delay the controller will wait for the input voltage to be within specifications, if the voltage is within specification the controller will turn off the fault indicators and attempt to restart the compressor. The voltage trip points are detailed below for each operating mode.

- **Power Fault and Short-Circuit (motor-phase to phase) Current Detection -----**
POWER FAULT - If the power into the motor exceeds 420 watts for more than 60 second the controller will fault delay for 60 seconds then attempt to restart.
OVER-CURRENT FAULT - The controller monitors the motor current and will turn the compressor off then set the fault output and display the appropriate fault message if the current exceeds an internal pre-determined current threshold. The controller will delay for 60 seconds before attempting to restart. The controller will attempt to start ten times. After the tenth cycle the controller will enter into a lockout state that requires a power cycle to clear the fault. *** When Lock-out has occurred the controller will turn the Fault LED ON. It will not flash when the controller is in lockout.
- **Power devices temperature above limit** - if the power devices have exceeded there maximum operating temperature 80°C the controller will turn the compressor off then set the fault output and display the appropriate fault message. The controller will delay for 60 seconds. After the delay the controller will monitor the power device temperature and if it has fallen below 80°C (176°F) the controller will clear the fault indicators and attempt to restart the compressor.
- **Fan Voltage Out of Tolerance** – The controller continuously monitors the fan voltage. If the fan voltage is outside of the specified region due to excessive load current the controller will turn the and fan output off and turn off the compressor. The controller will then set the fault output and display the appropriate fault message. The controller will delay for 60 seconds before attempting to turn the fan output on and restarting the compressor.
- **General Hardware Error** – This error occurs when one or more of several conditions are present in the system. The system consists of two uControllers, if the communication between the controllers is lost this can cause the error. Other examples of what can cause this error include: a difference of measured voltages, if the microcontrollers are measuring different voltages at the same point, and a difference in the current consumption measurements.

LED Fault Indicator and Fault output

The controller will signal a fault condition by outputting a logic high value on the fault output. The output is a TTL level signal capable of directly driving +/- 5mA. The controller will indicate a fault condition by flashing the fault LED. The Flashing pattern will be ¼ second on and ¼ second off for each count, then dwells 5 seconds and repeat until the fault(s) are cleared. Listed below are the fault codes.

If the controller enters fault lockout from over current faults the LED will stay lit and not flash.

- 1 flash – Motor Fault
- 2 flashes – Under Voltage
- 3 flashes – Over Voltage
- 4 flashes – Over Temperature
- 5 flashes – Over Current / Over Power
- 6 flashes – Fan Voltage out of Tolerance
- 7 flashes – General Hardware Error
- 8 flashes – System Integrity Fault

FAN output

Fan Power is on any time compressor is commanded to run and the fan fault is not active.

- The fan out is a current source. When the fan turns on it can support a current of 1A for 1 second. After the startup if the fan current exceeds 0.5A the controller will detect a voltage out of tolerance and then turn off the fan output and the compressor, set the fault output and display the appropriate fault message. The controller will delay for 60 seconds before attempting to turn on the fan output and restarting the compressor.

Serial Port Diagnostic Messages

The controller will report the model number on power up. The motor controller will report real time power device temperature, compressor speed, motor input voltage, compressor current and fault status on the serial port. Serial port configured for 19200 baud, 8 data bits, 1 stop bit, no parity, no flow control. Access to the connector will require the module to be disassembled.

This port is not intended for end use. It is only present for debugging and testing during the development and testing of the controller.

Engineering Specifications

Operating Characteristics

Parameter	Min.	Typical	Max.	Units	Comments
Output power:	0	-	420	W	
Input Voltage	39	48	60	VDC	Motor speed will be limited when input is below 48Volts
High voltage trip	59	60	61	VDC	
High voltage resume	58.5	59.5	60.5	VDC	
Low voltage trip	34	36	37	VDC	Default (programmable)
Low voltage resume	35	37	39	VDC	Default (programmable)
Power Devices Over Temperature Trip	80 (176)	85 (185)	90 (194)	°C (°F)	
Power Devices Over Temp fault Resume	75 (167)	80 (176)	85 (185)	°C (°F)	
Analog speed input:	0	-	5	V	
Analog Speed Input = 1V	1750	1800	1850	RPM	
Analog Speed Input = 4.75V	4150	4200	4250	RPM	
Analog Speed Input = .26V – 0.99V	0	-	-	RPM	OFF
Analog Speed Input = 0V-.25V	-	3000	-	RPM	
Fault Output VIH	4	-	-	V	4mA load
Fault Output IIH	-	-	4	MA	
Drive efficiency @ 180W –3000 RPM	92	-	100	%	
Rated input current	-	-	9	A	See Note 1
Fan Connector voltage	11.25	12	12.75	V	switched
Fan Connector current (peak)	-	1	-	A	For 1 second @ startup
Fan Connector current (average)	-	.5	-	A	
Quiescent current	-	-	30	mA	no motor running

Note: 1- No onboard fuse is supplied; however an external 10A inline fuse is required

Typical wiring diagram shown with optional R1 and R2 selected from charts below.



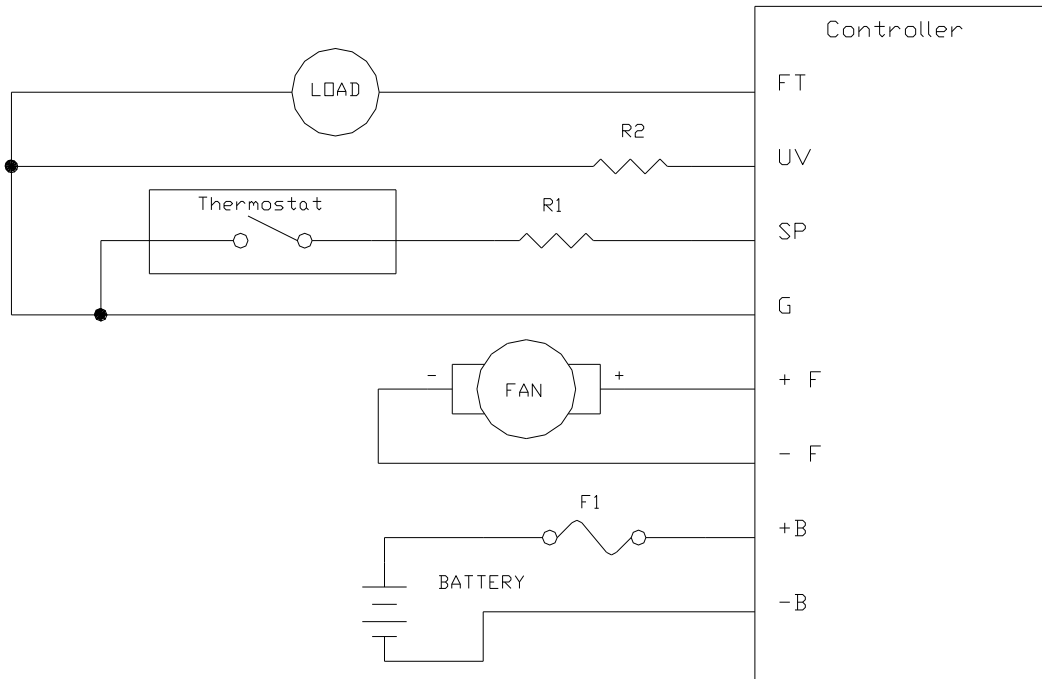

Optional Fixed resistor speed chart

Resistor Value R1	Motor Speed
OHMS	[RPM]
0	3000
200	1800
242	1900
287	2000
388	2200
510	2400
659	2600
847	2800
1090	3000
1.4k	3200
1.88k	3400
2.58k	3600
3.8k	3800
6.36k	4000
15.3k	4200

Use the formula below to find the resistor value needed to achieve a specific speed for the controller.

$$R = \frac{934960}{\text{SpeedDesired}} - 806$$

$$\text{SpeedDesired} = 4360$$

Optional under Voltage resistor selection chart

Resistor Value R2	48V Under Voltage	48V Resume
[k \wedge]	[V]	[V]
0	36.0	37.0
1.6	36.1	37.4
2.4	36.2	37.5
3.6	36.3	37.6
4.7	36.4	37.7
6.2	36.5	37.8
8.2	36.7	38.0
11	36.8	38.1
14	36.9	38.2
18	37.1	38.3
24	37.2	38.5
33	37.3	38.6
47	37.4	38.7
82	37.7	39.0
> 120	36.0	37.0

Environmental Ratings

Parameter	Comments	Min.	Max.	Units
Operating Temperature Range		0 (32)	45 (113)	$^{\circ}$ C ($^{\circ}$ F)
Storage Temperature		-40 (-40)	100 (212)	$^{\circ}$ C ($^{\circ}$ F)
Humidity (IEC68-2-30)	90 % +/- 5% Relative Humidity Non-condensing		95	%
Vibration and shock/ 5-500 Hz			10	Grms
Storage Vibe and Shock/ 5-500 Hz			20	Grms

Absolute Maximum Ratings

Parameter	Min.	Max.	Units
Speed Set-point	-0.3	5.05	V
+Vm voltage input	0	60	V
Fault output current	-5	5	MA

Connectors

Compressor power

3-position connector harness that mates with compressor pins.

Signal Name	Type
Phase A	Output
Phase B	Output
Phase C	Output

Power and Control I/O Connector

Pin	Signal Name	Type
FT	Fault TTL Output	Output
UV	Optional Battery protection Pin (resistor)	Input
SP	0-5V Speed Control	Input
G	Ground (signal return for inputs and output)	Input
+F	+Fan (optional 12V fan)	Output
-F	-Fan (optional 12V fan)	Output
+B	+ Battery	Input
-B	- Battery	Input

RoHS Compliance

This assembly is compliant to the RoHS directive set forth by the European Union