



MASTERFLUX

**Masterflux 24V Cascade
BLDC Motor Controller
Product Specification
030F0176**

Revision History

Date	ECN	Rev	Description	By
08/03/16	EC73464	A	Initial Release	R. Snyder
09/20/17	EC80597	B	Correct resistor table and speed description	D. Stahl



Table of Contents

REVISION HISTORY	1
TABLE OF CONTENTS	2
DEVICE OVERVIEW	4
Features.....	4
DESCRIPTION	4
OPERATION	5
Analog Speed Control (default).....	5
Fixed Speed Control	5
Fault Detection.....	5
LED Fault Indicator and Fault output.....	7
FAN output	7
ENGINEERING SPECIFICATIONS	8
OPERATING CHARACTERISTICS	8
ENVIRONMENTAL RATINGS	10
Absolute Maximum Ratings	11
MECHANICAL REQUIREMENTS	ERROR! BOOKMARK NOT DEFINED.
CONNECTORS	11
AGENCY REQUIREMENTS	11
RoHS Compliance	11



IMPORTANT PRODUCT NOTICE AND WARRANTY INFORMATION

All statements, technical information or data related to Masterflux products are based on information believed to be reliable. However, no representation or warranty, express or implied, is made as to their completeness, accuracy, fitness for a particular purpose or any other matter, including, without limitation, that the practice or application of any such statements, technical information or data is free of patent infringement or other intellectual property misappropriation.

All information provided in this specification is intended for persons having the requisite knowledge, skill, and expertise to properly and completely evaluate such information. Masterflux shall not be responsible or liable for the use, application or implementation of the information provided herein, and all such information is to be used at the risk, and in the sole judgment and discretion, of such persons, their employees, advisors and agents and only after their independent evaluation and determination that the product is suitable for the application intended by such persons.

Masterflux is not in the business of providing technical, engineering or operational information for a fee, and, therefore, any such information is provided as an accommodation and without charge. Masterflux reserves the right to make changes to its products or to discontinue any product at any time without notice, and advises customers to obtain the latest relevant information prior to ordering.

Limited WARRANTY; DISCLAIMER OF WARRANTY; LIMITED REMEDY; LIMITED LIABILITY

All Masterflux products are sold subject to the terms and conditions of sale supplied at the time of order acknowledgement, including, but not limited to, those pertaining to warranty (as stated in its “Warranty to Original Equipment Manufacturers”), patent infringement, and limitation of liability. MASTERFLUX MAKES NO OTHER WARRANTIES INCLUDING, BUT NOT LIMITED TO, ANY IMPLIED WARRANTY OF MERCHANTABILITY OR FITNESS FOR A PARTICULAR PURPOSE INCLUDING, WITHOUT LIMITATION, ANY WARRANTY THAT MASTERFLUX PRODUCTS ARE SUITABLE OR FIT FOR USE IN ANY HUMAN SAFETY OR LIFE SUPPORT SYSTEMS. If a Masterflux product is found to be defective in materials or workmanship within the warranty period set forth in the “Warranty to Original Equipment Manufacturers,” Masterflux’s sole and exclusive obligation, exercisable in its sole discretion, shall be to repair or replace the product or refund the purchase price of the product as more fully set forth in the “Warranty to Original Equipment Manufacturers.”

Masterflux will not be liable for any loss or damage arising from any Masterflux product, whether direct, indirect, special, incidental or consequential, regardless of the legal theory asserted, even if Masterflux shall have been advised of the possibility of such potential loss or damage.



Device Overview

Features

- 4 poles sensor-less variable speed BLDC motor controller
- 420 W maximum output power
- 19 – 30 VDC input range
- 48V motor supply (voltage boost)
- 1800 – 4200 rpm speed
- 1.0 - 4.75V analog speed set input (resistor programmable for fixed speed)
- 0 to +45°C operating temperature static air
- Under/Over voltage shutdown (resistor programmable under voltage thresholds)
- Locked rotor detection
- Thermal shutdown – for power devices
- Over current shutdown – for power devices
- Low speed shutdown
- TTL Fault output
- LED fault indicator
- Fan output, +12VDC @ 0.5A with voltage detection
- Reverse polarity protection
- Flat Plate Heat Sink

Description

The TH motor controller has been designed to provide efficient control and monitoring of a 4 pole 48VDC brushless/sensor-less hermetic TH compressor. The controller will provide a constant speed as specified by the speed command input (1800 - 4200 RPM) unless one of the following limitations occurs.

Power limitation, this limits the average power the drive is puts into the motor. If the load requires more than 420 watts into the motor the controller will fault and shut down the motor.

The compressor on/off operation and the speed is controlled by 0V – 5V analog input. For fixed speed applications a resistor can be installed between ground at the controller and the speed input.

(see resistor selection chart)

The controller is designed to work in ambient temperatures from 0°C (32°F) to +45°C (113°F) static air and presents several fault sensors to protect the module, the power supply and the compressor. Higher operating temperatures can be achieved with active cooling. Visual Fault information is available through an LED that is uniquely flashed for each fault condition. A TTL fault output is also available that is high when fault is active.



Operation

Analog Speed Control (default)

A 0 - 5VDC non-isolated analog input can be used to control the motor speed and off / on operation. When the analog input is below 0.8V or greater than 4.85V the controller is in normal mode and the compressor is off. If the analog input is above 0.9V and below 4.85V the compressor will start and ramp up at a rate of 600 RPM per second to the commanded speed. The speed command is mapped to 1.0V is 1800 RPM and 4.75V is 4200 RPM. Once the motor begins to run it will require the input voltage to go lower than 0.8 V to stop the motor (hysteresis). The motor controller will run the motor at the set-point speed unless a voltage, current or power limitation is exceeded.

Fixed Speed Control

A fixed motor speed can be set through an external resistor connected between ground at the controller and the speed input. A switch in series with the resistor can be used to turn the motor on and off in this configuration. See speed resistor selection chart.

Fault Detection

The compressor is turned off when any of the faults described below are detected. Faults are indicated on the fault output pin and flashed on the LED. The fan output is disabled for all faults except motor faults where the fan output will continue to be active if the run command is present.

Faults

- **Motor Fault** – If the compressor fails to start the fault output will be activated and a motor fault will be indicated on the LED. The controller will delay for 60 seconds before attempting to restart. Also the compressor must maintain a minimum speed of 1400 RPM for proper lubrication. If the controller is unable maintain 1400 RPM it will turn the compressor off then set the fault output and display motor fault. The controller will delay for 60 seconds before attempting to restart. If a motor fault occurs and the controller is commanded to run the fan output will continue to be active during the 60 second fault timer. All other fault conditions the fan output will be disabled until the fault is cleared.
- **Under/Over voltage** - The controller will continuously monitor the input voltage, if the input voltage exceeds the upper or lower limits it will turn the compressor off and set the fault output and display the appropriate fault message on the LED. The controller will then delay for 60 seconds. After the delay the controller will wait for the input voltage to be within specifications, if the voltage is within specification the controller will turn off the fault indicators and attempt to restart the compressor. The voltage trip points are detailed below for each operating mode.



- **Short-Circuit (motor-phase to phase) Current Detection** – The controller monitors the motor current and will turn the compressor off then set the fault output and display the appropriate fault message if the current exceeds an internal pre-determined current threshold or max power limit set to 420 watts. This is the motor current * motor voltage. If it exceeds 420 watts for 30 seconds the controller will fault. Then the controller will delay for 60 seconds before attempting to restart. The controller will attempt to start ten times. After the tenth cycle the controller will enter into a lockout state that requires a power cycle to clear the fault. *** When Lock-out has occurred the controller will turn the Fault LED ON. It will not flash when the controller is in lockout.
- **Power devices temperature above limit** - if the power devices have exceeded there maximum operating temperature 80°C the controller will turn the compressor off then set the fault output and display the appropriate fault message. The controller will delay for 60 seconds. After the delay the controller will monitor the power device temperature and if it has fallen below 80°C (176°F) the controller will clear the fault indicators and attempt to restart the compressor.
- **Fan Voltage Out of Tolerance** – The controller continuously monitors the fan voltage. If the fan voltage is outside of the specified region due to excessive load current the controller will turn the and fan output off and turn off the compressor. The controller will then set the fault output and display the appropriate fault message. The controller will delay for 60 seconds before attempting to turn the fan output on and restarting the compressor.
- **General Hardware Error** – This error occurs when one or more of several conditions are present in the system. The system consists of two Controllers, if the communication between the controllers is lost this can cause the error. Other examples of what can cause this error include: a difference of measured voltages, if the microcontrollers are measuring different voltages at the same point, and a difference in the current consumption measurements.



LED Fault Indicator and Fault output

The controller will signal a fault condition by outputting a logic high value on the fault output. The output is a TTL level signal capable of directly driving +/- 5mA. The controller will indicate a fault condition by flashing the fault LED. The Flashing pattern will be ¼ second on and ¼ second off for each count, then dwells 5 seconds and repeat until the fault(s) are cleared. Listed below are the fault codes.

If the controller enters fault lockout from over current faults the LED will stay lit and not flash.

- 1 flash – Motor Fault
- 2 flashes – Under Voltage
- 3 flashes – Over Voltage
- 4 flashes – Over Temperature
- 5 flashes – Over Current
- 6 flashes – Fan Fault
- 7 flashes – General Fault
- 8 flashes – System integrity Fault

FAN output

Fan Power is on any time compressor is commanded to run and the fan fault is not active.

- The fan out is a current source. When the fan turns on it can support a current of 1A for 1 second. After the startup if the fan current exceeds 0.5A the controller will detect a voltage out of tolerance and then turn off the fan output and the compressor, set the fault output and display the appropriate fault message. The controller will delay for 60 seconds before attempting to turn on the fan output and restarting the compressor.



Engineering Specifications

Operating Characteristics

Parameter	Min.	Typical	Max.	Units	Comments
Output power:	0	-	420	W	
Input Voltage	21	24	28	VDC	
	0		1	V/mS	Maximum slew rate
High voltage trip	29	30	31	VDC	
High voltage resume	28	29	30	VDC	
Low voltage trip	18	19	20	VDC	Default (programmable)
Low voltage resume	19	20	21	VDC	Default (programmable)
Power Devices Over Temperature Trip	95	85	105	°C	
	(203)	(212)	(221)	(°F)	
Power Devices Over Temp fault Resume	75	80	85	°C	
	(167)	(176)	(185)	(°F)	
Analog speed input:	0	-	5	V	
Analog Speed Input = 1V	1750	1800	1850	RPM	
Analog Speed Input = 4.75V	4150	4200	4250	RPM	No load Speed
Analog Speed Input < 0.8V	0	-	-	RPM	
Analog Speed Input > 4.85V	0	-	-	RPM	
Fault Output V _{IH}	4	-	-	V	4mA load
Fault Output I _{IH}	-	-	4	MA	
Drive efficiency @ 250W –3600 RPM	92	-	100	%	
Rated input current	-	-	20	A	At 20V input - See Note 1
Fan Connector voltage	11.25	12	12.75	V	switched
Fan Connector current (peak)	-	1	-	A	For 1 second @ startup
Fan Connector current (average)	-	.5	-	A	
Quiescent current	-	-	30	mA	@24V no motor running

Note: 1- No onboard fuse is supplied; however an external 25A inline fuse is required



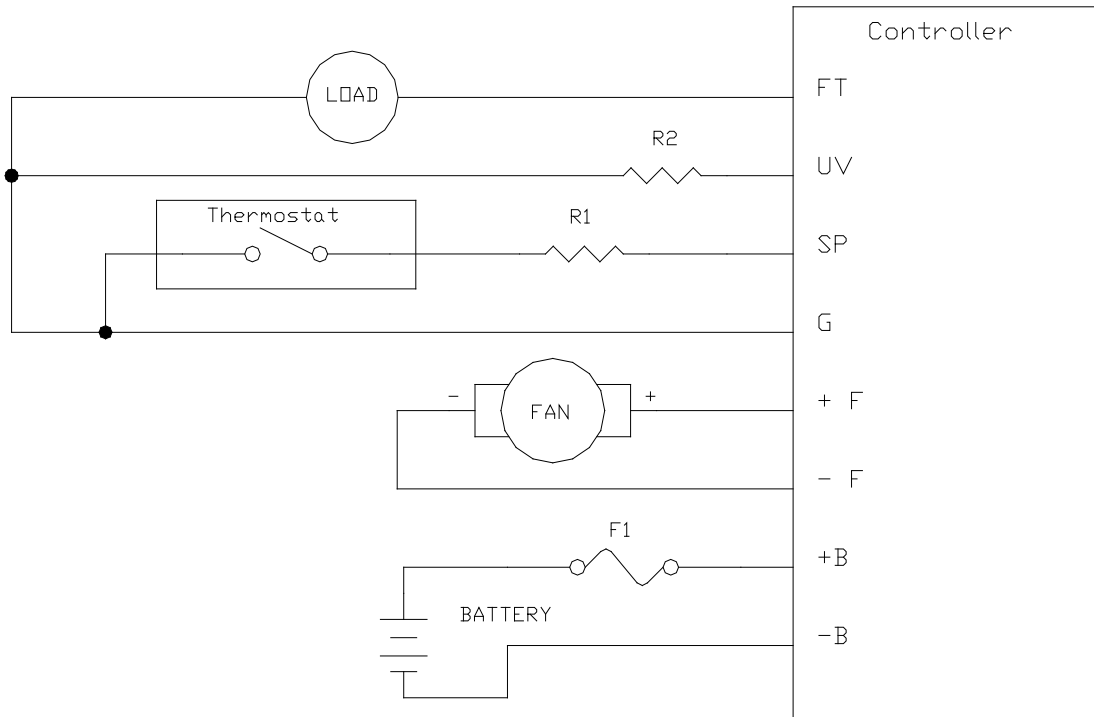

Typical wiring diagram shown with optional R1 and R2 selected from chars below.

Use the formula below to find the resistor value needed to achieve a specific speed for the controller.

Resistor Value R1	Motor Speed
OHMS	[RPM]
200	1800
242	1900
287	2000
388	2200
510	2400
659	2600
847	2800
1090	3000
1.4k	3200
1.88k	3400
2.58k	3600
3.8k	3800
6.36k	4000
15.3k	4200

$$\frac{934960 - 806 \cdot \text{SpeedDesired}}{\text{SpeedDesired} - 4360}$$

Optional under voltage resistor selection chart

Resistor Value R2	Under Voltage	Resume
[k \wedge]	[V]	[V]
0	19.2	20.2
1.6	19.4	20.4
2.4	19.6	20.6
3.6	19.8	20.8
4.7	20.0	21.0
6.2	20.2	21.2
8.2	20.4	21.4
11	20.6	21.6
14	20.8	21.8
18	21.0	22.0
24	21.2	22.2
33	21.4	22.4
47	21.6	22.6
82	21.8	22.8
> 120	19.0	20.0

Optional Fixed resistor speed chart

Environmental Ratings

Parameter	Comments	Min.	Max.	Units
Operating Temperature Range	Static air <i>*Higher operating temperatures can be achieved with active cooling</i>	0 (32)	45 (131)	°C (°F)
Storage Temperature		-40 (-40)	100 (212)	°C (°F)
Humidity (IEC68-2-30)	90 % +/- 5% Relative Humidity Non-condensing		95	%
Vibration and shock/ 5-500 Hz			10	Grms
Storage Vibe and Shock/ 5-500 Hz			20	Grms



Absolute Maximum Ratings

Parameter	Min.	Max.	Units
Speed Set-point	-0.3	5.05	V
+Vm Power input	0	36	V
Fault output current	-5	5	MA

Connectors

Compressor power

3-position connector harness that mates with compressor pins.

Signal Name	Type
Phase A	Output
Phase B	Output
Phase C	Output

Power and Control I/O Connector

Pin	Signal Name	Type
FT	Fault TTL Output	Output
UV	Optional Battery protection Pin (resistor)	Input
SP	0-5V Speed Control	Input
G	Ground (signal return for inputs and output)	Input
+F	+Fan (optional 12V fan)	Output
-F	-Fan (optional 12V fan)	Output
+B	+ Battery	Input
-B	- Battery	Input

Agency Requirements

RoHS Compliance

This assembly is compliant to the RoHS directive set forth by the European Union

